

2.1 - Experiments and studies with EMMS

D.C. Motors & Generators

- Connection and study of industrial type of Dc. machines operation, used as motors and generators
- Operation with starter and field regulator
- Reversing rotation and speed regulation
- Measure of armature and excitation voltage and current
- Speed and torque detection
- Load characteristics with mechanical or magnetic brake
- Characteristic with variable R-load
- Adsorbed power, mechanical losses, iron losses, copper losses, efficiency
- Comparison between shunt, series and compound connections
- Shunt connection of two generators
- Operation with electronic speed control

A.C. 3-phase Machines

- Operation with connection to power
- Starting techniques: star-delta circuits, series resistance auto-transformer starter
- Reversing rotation and speed adjustment
- Measure of current and voltage values
- Load characteristics (recording with an electromagnetic brake or magnetic powder brake or DC brake generator)
- Draw of circular diagram and its practical use
- Real and reactive power, mechanical power
- Power factor ($\cos \varphi$) efficiency and slip
- Adsorbed power
- Output power regulation
- Shunt connection and synchronisation between two three-phase synchronous generators
- Main synchronisation techniques
- "V" characteristics: stability – limits
- Operation as rotating capacitor / inductor
- Three-phase shifter operation
- Operation with electronic speed control
- Fault finding:
 - Winding break in a coil
 - Winding to winding short
 - Coil to coil short/ Insulation fault.

A.C. Single Phase Motors

- Operation with connection to power
- Starting techniques according to the machine type
- Reversing rotation and speed adjustment
- Influence of brush position on the speed
- Measure of current and voltage values
- Load characteristics (recording with an electromagnetic brake or magnetic powder brake).

1-PH / 3-PH Transformers

- Operation with connection to power
- Star-Delta, Zig-Zag and Scott connections
- Current and voltage measure at open circuit
- Current and voltage measure at full load and short circuit conditions
- Shunt connection between two transformers
- Load distribution.



The machines of this system can be supplied with a suitable base that allows an easy and safe coupling with other machines. It is fast and easy to realise groups of machines.

Special didactic solutions have been introduced in order to simplify the approach of the student to the study.

Connection example 1

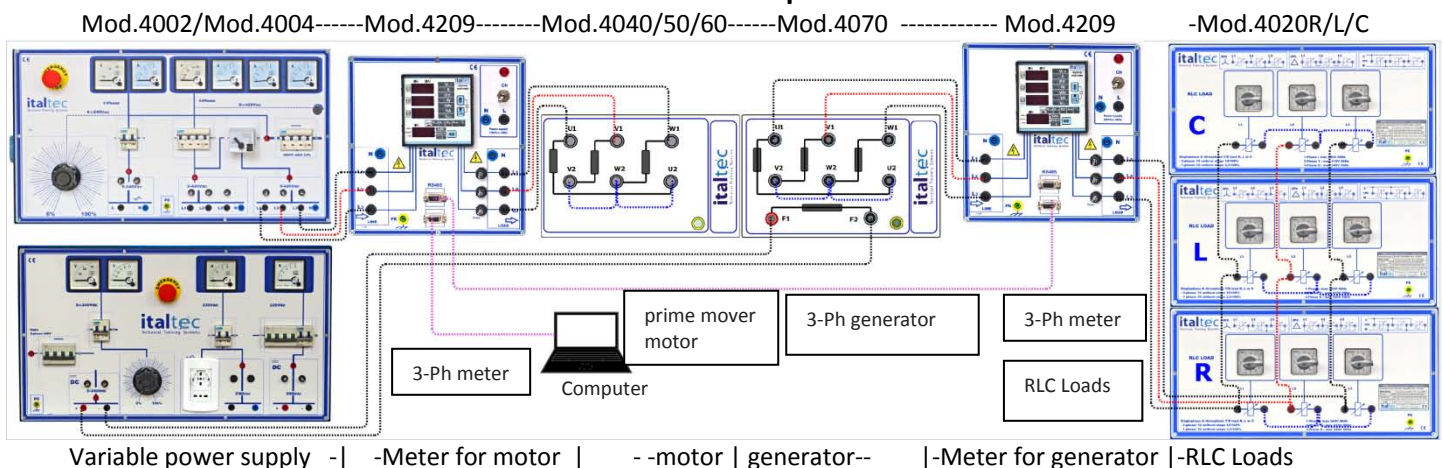

2.2 - Experiments and studies with EMMS

Connection example 2

Mod.4002/Mod.4004-----Mod.4209-----Mod.4040/50/60---Mod.4140/50/60 ---- Mod.4203-02 -Mod.4020-10R

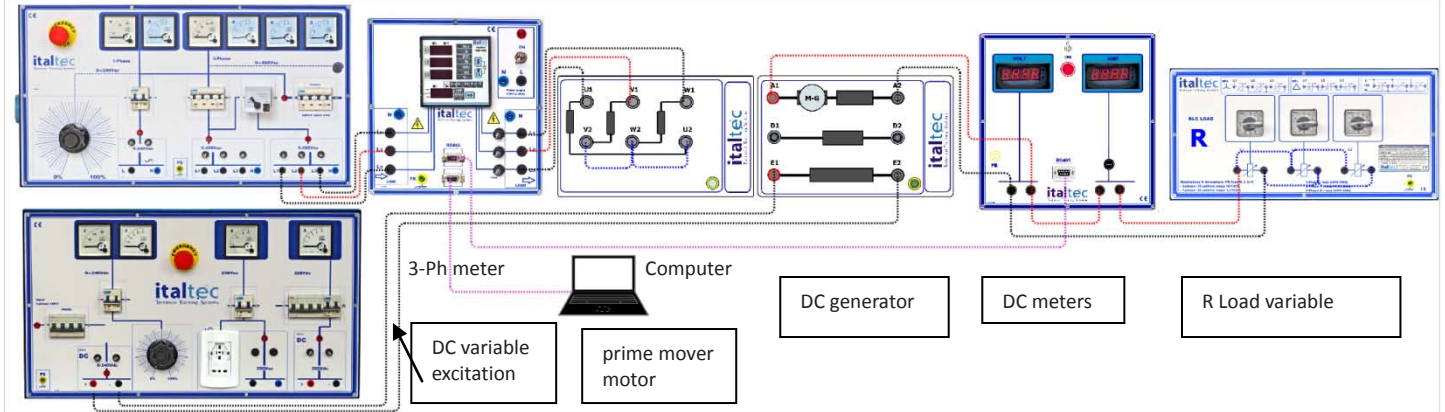

Variable power supply - | -Meter for motor | - motor | generator-- | -Meter for generator | -RLC Loads

Connection example 3

Mod.4002/Mod.4004-----Mod.4209-- -----Mod.4040/50/60-----Mod.4180 -----Mod.4203-07

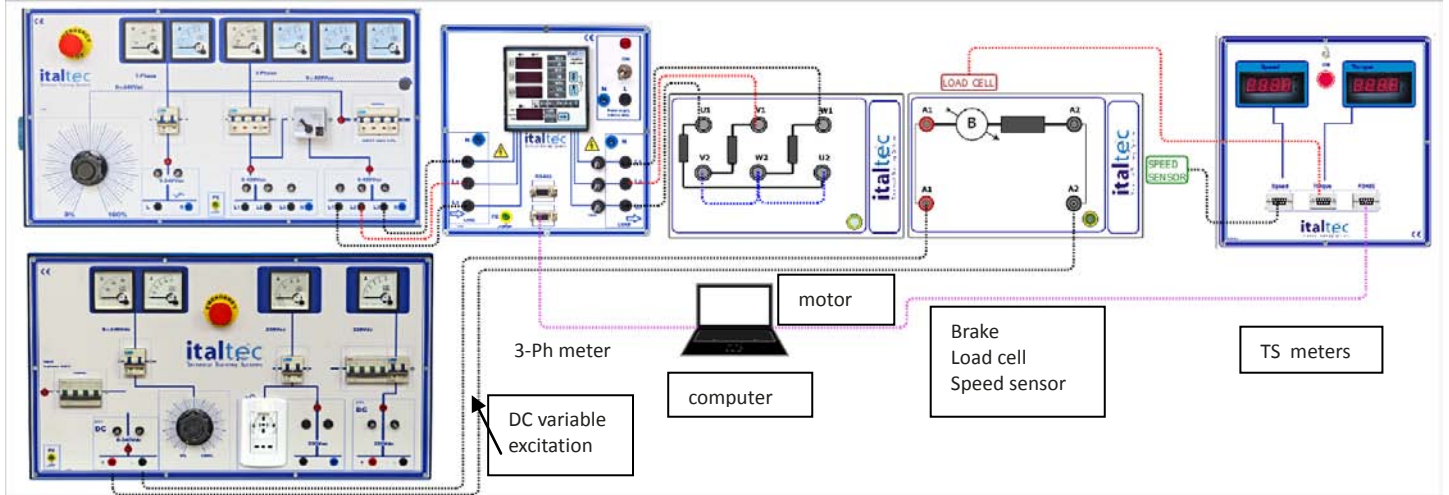

Variable power supply - | -Meter for motor | - motor | brake-- | - Torque & speed meter

Connection example 4

Mod.4002/Mod.4004-----Mod.4203-02-- --Mod.4140/50/60-----Mod.4180 -----Mod.4203-07

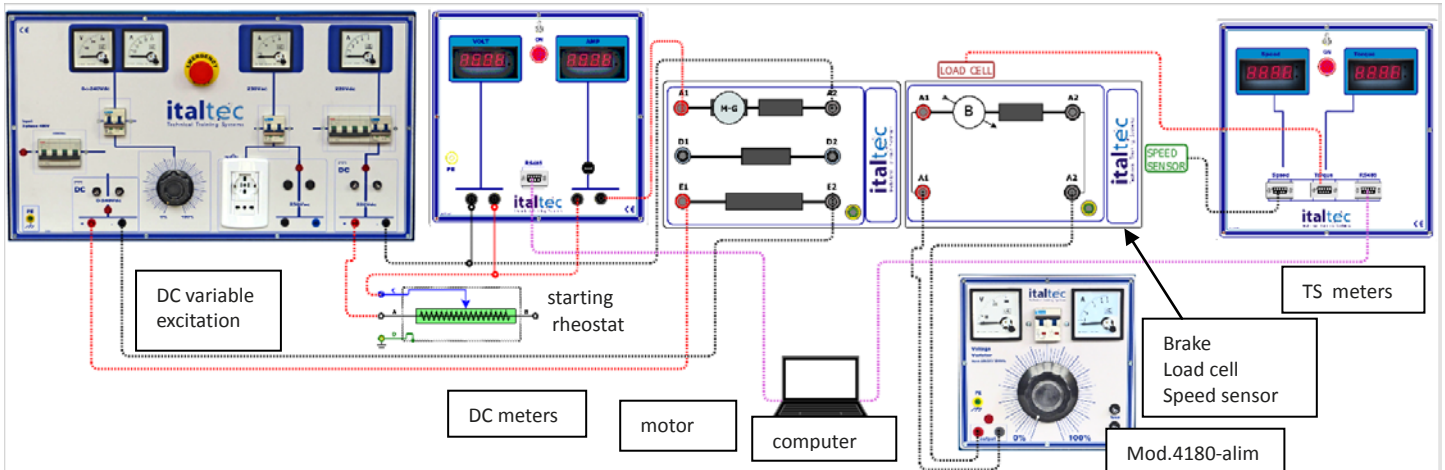

Variable power supply - | -Meter for motor | - Motor | Brake-- | -Torque & speed meters